

“Education's purpose is to replace an empty mind with an open one.”
~**Malcolm S. Forbes**

Congratulations on moving on! Your first year will begin shortly and you should prepare yourself for what's ahead!



Here's what to do:

- Print out each packet
- Work on each one throughout the summer
- Show all of your work right on the packet (Do not use a separate sheet of paper)
- Bring your packets with you on the first day of school in September

*****Calculators are NOT allowed, unless only used to check your work!*****

You will receive a TEST GRADE for the entire packet! This will be your first test grade of the year, so let's start off on the right foot! There might be questions in the packets that you do not know how to do; credit will be given if you showed you tried!

Remember...if you need a little extra help, you can visit these websites!

<http://www.classzone.com>
<http://www.mathwords.com>
<http://mathworld.wolfram.com>
<http://www.purplemath.com>
<http://www.mathisfun.com>
<http://www.math-drills.com>



Keep working hard & enjoy your summer vacation!
See you in September!

“El propósito de la educación es para reemplazar una mente vacía con una abierta.”

Malcolm S. Forbes

Felicidades en tu progreso! Tu primer año empezará pronto y debes prepararte para lo que te espera.



Debes hacer lo indicado:

- Imprimir cada pagina asignada para el verano
- Trabajar cada uno durante el verano
- Debe enseñar el trabajo hecho en las paginas (No use paginas separada de papel)
- Traer todo su trabajo con usted el primer día de escuela en septiembre

*****Por favor no usen CALCULADORAS, únicamente para revisar los resultados.*****

Se le asignará una CALIFICACION que equivale al grado de su examen por todo el trabajo. Esta será su primera calificación del año, así podremos empezar con una actitud positiva en este nuevo año. Habrá algunas preguntas que usted no sabrá como hacerlas, pero se le dará crédito si demuestra que lo probaste.

Recuerde...si necesita ayuda usted puede visitar las siguientes direcciones electrónicas:

<http://www.classzone.com>

<http://www.mathwords.com>

<http://mathworld.wolfram.com>

<http://www.purplemath.com>

<http://www.mathisfun.com>

<http://www.math-drills.com>



¡Continué trabajando duro y disfrute sus vacaciones del verano!

¡Nos vemos en septiembre!

INTEGERS

Add.

- $(-34) + (-77) = \underline{\hspace{2cm}}$
- $(-32) + 19 = \underline{\hspace{2cm}}$
- $42 + (-45) = \underline{\hspace{2cm}}$
- $(-55) + (-7) = \underline{\hspace{2cm}}$
- $3 + (-6) + 12 = \underline{\hspace{2cm}}$
- $(-9) + (-6) + (-15) = \underline{\hspace{2cm}}$

Subtract.

- $15 - (-3) = \underline{\hspace{2cm}}$
- $(-7) - 1 = \underline{\hspace{2cm}}$
- $(-4) - (-6) = \underline{\hspace{2cm}}$
- $36 - (-41) = \underline{\hspace{2cm}}$
- $(-1) - 6 - (-9) = \underline{\hspace{2cm}}$
- $21 - (-12) - 12 = \underline{\hspace{2cm}}$

Multiply or divide.

- $(-4) \bullet (-10) = \underline{\hspace{2cm}}$
- $86 \bullet (-6) = \underline{\hspace{2cm}}$
- $(-52) \div 13 = \underline{\hspace{2cm}}$
- $164 \div (-4) = \underline{\hspace{2cm}}$
- $(-5) \bullet (-13) \bullet (-4) = \underline{\hspace{2cm}}$
- $204 \div (-3) \bullet (-7) = \underline{\hspace{2cm}}$

Find each absolute value.

- $|-15| = \underline{\hspace{2cm}}$
- $|11 - 14| = \underline{\hspace{2cm}}$
- $|-5,187| = \underline{\hspace{2cm}}$
- $|(-43) \bullet (-8)| = \underline{\hspace{2cm}}$



Challenge Problem!

Evaluate.

- $[2 + (-4)] + 5 - [(-11) \bullet (-2)] - (-7) = \underline{\hspace{2cm}}$

EQUATIONS & INEQUALITIES

Solve.

1. $x - 7 = 86$

2. $7 + 3y = -14$

3. $5b + 7b = 60$

4. $\frac{f}{6} - 1.2 = -30$

5. $4(w - 9) + 7w = 52$

6. $1.5x - 1.2 = 1.8x$

7. $-77 = -x + 55$

8. $5y + 20 = 0$

9. $-4.42y + 0.9 = -9.070 - 0.432y$

Solve and graph.

1. $10 + 4y < 18$

2. $4x + 7 \geq 11$

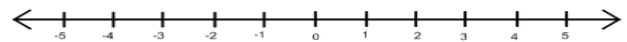
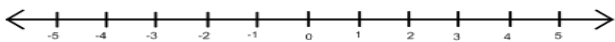

3. $-13x < 52$

4. $7m - 3m \geq -4$

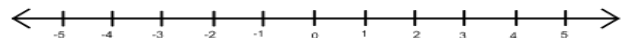
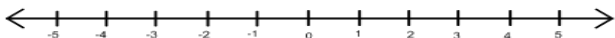

FRACTIONS/DECIMALS/PERCENTS

Use $>$, $<$, or $=$ to compare each pair of numbers.

1. $\frac{7}{8}$ _____ 0.82

2. -0.63 _____ $-\frac{5}{8}$

3. $1\frac{4}{5}$ _____ $\frac{21}{12}$

4. $-3\frac{1}{4}$ _____ $-3\frac{6}{25}$

5. $\frac{15}{27}$ _____ $\frac{16}{24}$

6. $\frac{8}{25}$ _____ 0.32

Write each percent as a decimal and as a fraction/mixed number in lowest terms.

	Decimal	Fraction/Mixed Number
1.	82% _____	_____
2.	60% _____	_____
3.	8% _____	_____
4.	135% _____	_____

Order each group of numbers from least to greatest. Write your answer on the line.

1. $0.7, 0.\bar{7}, \frac{3}{4}, \frac{7}{8}$

2. $-2\frac{2}{3}, -2\frac{2}{5}, -2.1, -2.25$

Challenge Problem!



Complete the statement using $>$, $<$, or $=$.

1. 25% of 80 _____ 125% of 12

FRACTION OPERATIONS

Add, subtract, multiply, or divide. All answers must be in fraction/mixed number form.

1. $7\frac{3}{11} - 4\frac{13}{33} = \underline{\hspace{2cm}}$

2. $5\frac{9}{20} + 1\frac{3}{5} = \underline{\hspace{2cm}}$

3. $7\frac{3}{5} - \frac{4}{5} = \underline{\hspace{2cm}}$

4. $\left(-\frac{3}{8}\right) + \left(-\frac{9}{20}\right) = \underline{\hspace{2cm}}$

5. $(-4) \cdot \frac{3}{5} = \underline{\hspace{2cm}}$

6. $\frac{3}{8} \div \frac{7}{12} = \underline{\hspace{2cm}}$

7. $\left(6\frac{3}{16}\right) \cdot \left(3\frac{1}{5}\right) = \underline{\hspace{2cm}}$

8. $15 \div \left(-4\frac{1}{6}\right) = \underline{\hspace{2cm}}$

DECIMAL OPERATIONS

Add, subtract, multiply, or divide. All answers must be in decimal form.

1. $0.1465 + 0.28 =$ _____

2. $13.87 - 6.8412 =$ _____

3. $7.039 \cdot (-0.04) =$ _____

4. $(-4.844) \div (-0.56) =$ _____

5. $1.57 - 9.28 =$ _____

6. $1.4678 + (-1.564) =$ _____

7. $(-9.767) \cdot (-4.089) =$ _____

8. $37.41 \div (-4.3) =$ _____

DATA, STATISTICS, & PROBABILITY

Find the mean, median, mode, and range for each set of data. Then display the data in a stem-and-leaf plot AND a box-and-whisker plot.

1. 30, 38, 42, 38, 17

Mean_____ Median_____ Mode_____ Range_____



2. 518, 581, 508, 588, 580

Mean_____ Median_____ Mode_____ Range_____



Find the probability.

1. A bag contains 5 red, 6 blue, 7 yellow, and 8 purple marbles. What is the probability that you randomly choose a marble that is not purple?

2. The spinner at the right is divided into equal parts. What is the probability that the pointer lands on:

- A prime number? _____
- An even number? _____
- The number 3? _____



GEOMETRY

In the following diagram, lines a & b are parallel and line t is a transversal line. The measure of angle 8 is 117° . Use this information to answer the questions.

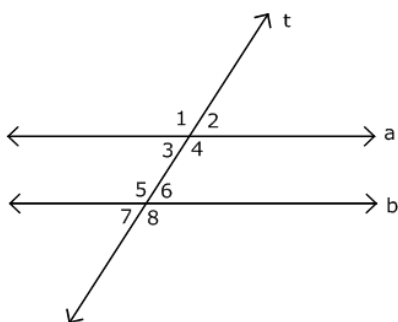

1. Name both pairs of alternate interior angles.

2. $m\angle 2 =$ _____

3. Name a pair of corresponding angles.

4. $m\angle 5 =$ _____

5. Name a pair of vertical angles. _____

6. Name both pairs of alternate exterior angles. _____

7. What kind of angles are $\angle 1$ & $\angle 2$? _____

In the following diagram, quadrilateral $KLMN \cong$ quadrilateral $SPQR$. Use this information to answer the questions.

1. $m\angle S =$ _____

2. Find the length of $\overline{NK} =$ _____

3. $m\angle LMN =$ _____

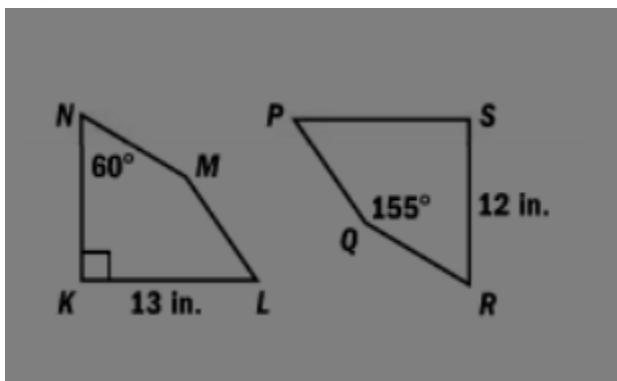

In the following diagram, $CDFG \sim HJLK$. Use this information to find the value of x .

1. $x =$ _____

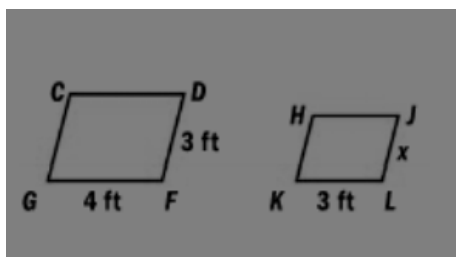

Name the quadrant or place in which each point lies.

1. $(-4, -2)$ _____ 2. $(0, -7)$ _____ 3. $(0,0)$ _____
4. $(6, -9)$ _____ 5. $(3, 5)$ _____ 6. $(8, 0)$ _____

Graph and label (with letters) these figures on the same plane.

1. PQRS: $P(-2,4), Q(-5,4), R(-8,0), S(-2,0)$
TUVW: $T(4,8), U(8,8), V(8,0), W(4,0)$
ABC: $A(0,-3), B(0,-7), C(-6,-7)$
DEFG: $D(3,-1), E(5,-3), F(3,-5), G(0,-5)$

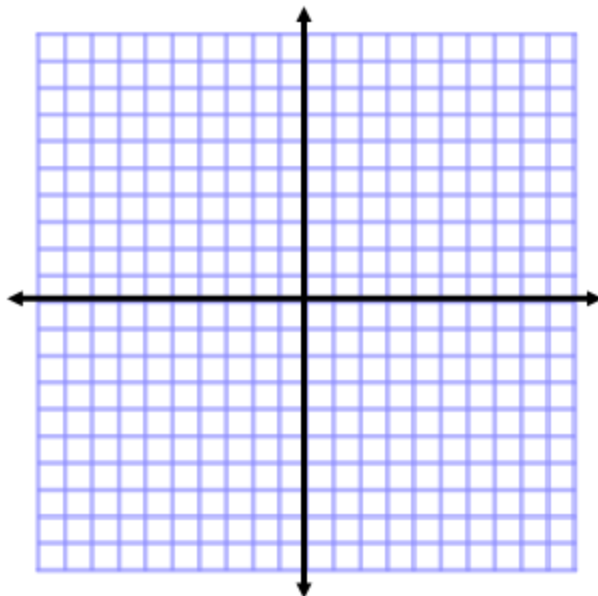

EXPRESSIONS & EXPONENTS

Evaluate for the given value. Write your answer on the line.

1. $4x - 5$, for $x = 7$

2. $(a \div b)^2 + (a \bullet b)$, for $a = 77$ & $b = 11$

3. $\frac{50 - x}{y + 3}$, for $x = 5$ & $y = -5$

4. $-8(b - c) + 8(b + c)$, for $b = 3$ & $c = -3$

Evaluate each expression.

1. $(2 + 1)^4 \div 9 - 4 =$ _____

2. $(5 \bullet 3)^2 - (63 \div 7)^3 =$ _____

3. $\frac{3}{4} \bullet 4 + 6^2 \div 9 =$ _____

4. $[(9 - 7)^5 + 17] \div \left(-\frac{1}{7}\right) =$ _____

RATIOS, PROPORTIONS, & PERCENTS

Find the unit rate.

1. $\frac{\$56}{8\text{lbs}} = \underline{\hspace{2cm}}$ 2. 7 phone calls in 2 hours = $\underline{\hspace{2cm}}$

Write the ratio as a fraction in simplest form.

1. 65 to 130 = $\underline{\hspace{2cm}}$ 2. $\frac{18}{63} = \underline{\hspace{2cm}}$

Solve each proportion by cross-multiplying.

1. $\frac{20}{x} = \frac{16}{5}$ 2. $\frac{y}{22} = \frac{11}{5.5}$ 3. $\frac{3.6}{3} = \frac{b}{14.4}$

Find each value.

- 60% of 25 is what number? $\underline{\hspace{2cm}}$
- 18 is 45% of what number? $\underline{\hspace{2cm}}$
- What percent of 600 is 180? $\underline{\hspace{2cm}}$
- The cost of a meal is \$35.27 and you leave an 18% tip. What is the total cost of the meal? Round to the nearest cent. $\underline{\hspace{2cm}}$
- You spend \$124.00 shopping, but the store is offering a 30% discount. What is the total cost after the discount? Round to the nearest cent. $\underline{\hspace{2cm}}$

MEASUREMENT, AREA, & VOLUME

Find the area of each figure.

1.

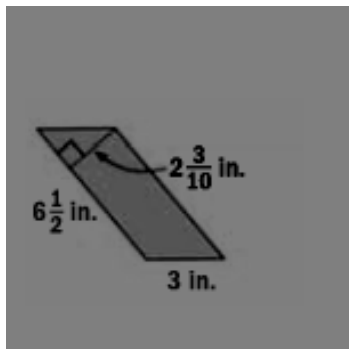

2.

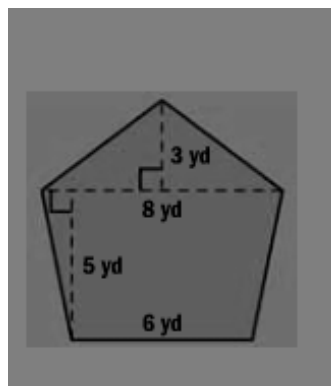

Use the Pythagorean Theorem (Formula) to find the missing side length.

1. $a = ?$, $b = 9$ ft, & $c = 15$ ft

2. $a = 0.9$ cm, $b = 1.2$ cm, & $c = ?$

Find the volume of each figure. Use 3.14 for π .

1.

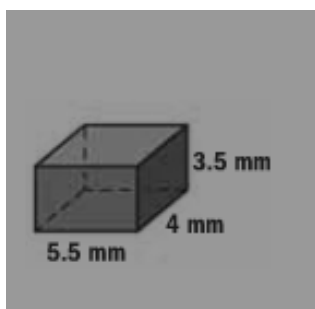

2.

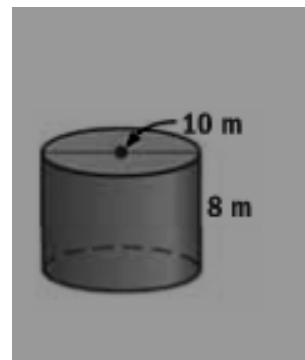

In this cylinder, the diameter is 10m.